

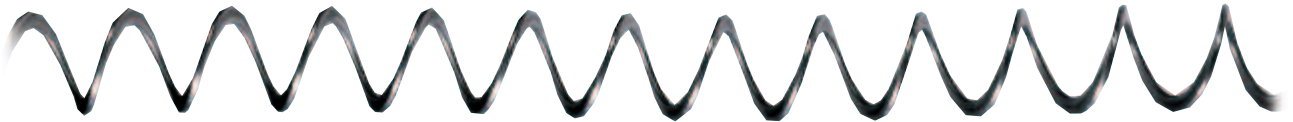

Big Dutchman®

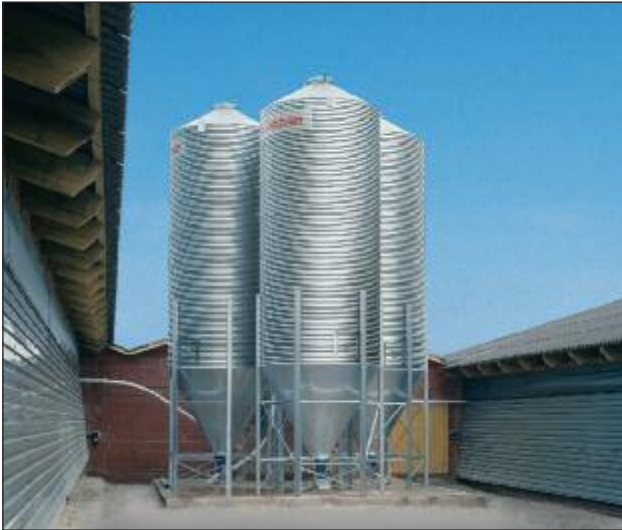

Silos and augers

Feed storage and transport systems

Silos – the base for hygienic feed storage

Big Dutchman offers you high quality silos for inside and outside use along with all the accessories you need for hygienic feed storage.

This includes:

- ✓ silos made of galvanized sheet steel

- ✓ silos made of glass-fiber reinforced plastic (GRP)
- ✓ inside silos made of Trevira fabric.

You can choose the right silo of the appropriate size out of a wide range of products. All systems can be filled pneumatically or

by auger.

The respective silo size depends on daily feed consumption and required storage time.

Advantages

- ✓ high-quality zinc-aluminium coating of all steel parts (type BD-P and BD-M), and use of glass-fiber reinforced plastic for improved corrosion protection and a long service life;
- ✓ trouble-free feed withdrawal due to optimum degree of slope in the silo funnel;
- ✓ auger box either rigid or flexible, adjustable from 0 to 45° – ensures operational safety;
- ✓ roof shape ensures use of the entire volume;
- ✓ the use of GRP silos allows simple checking on feed level due to the transparency of the material;
- ✓ high functional reliability.

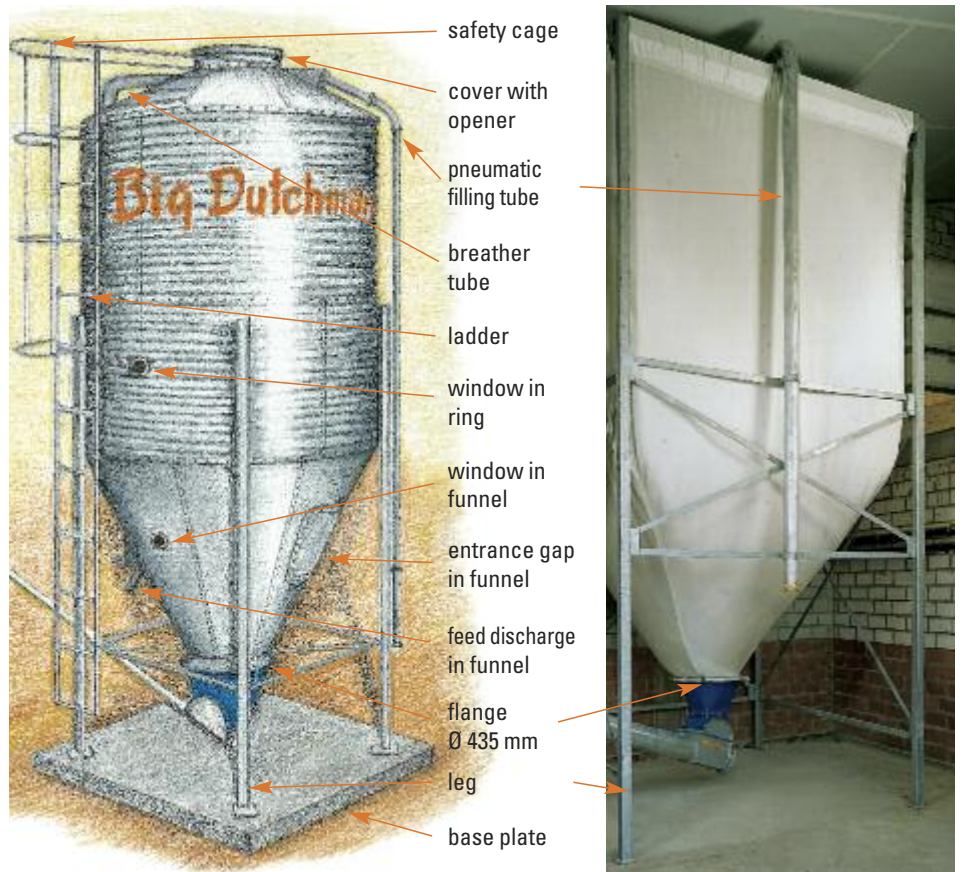

A number of options – spirals, augers and chain conveyors – are available for transport

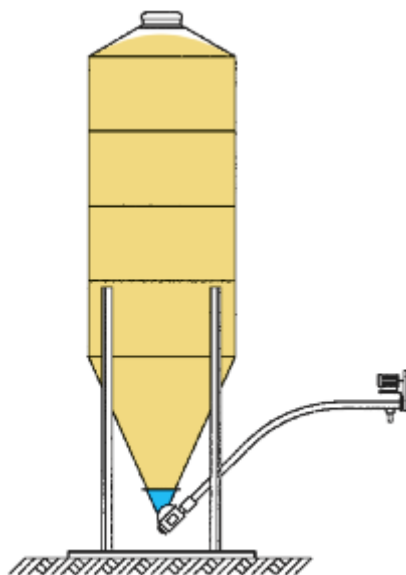

Flex Vey

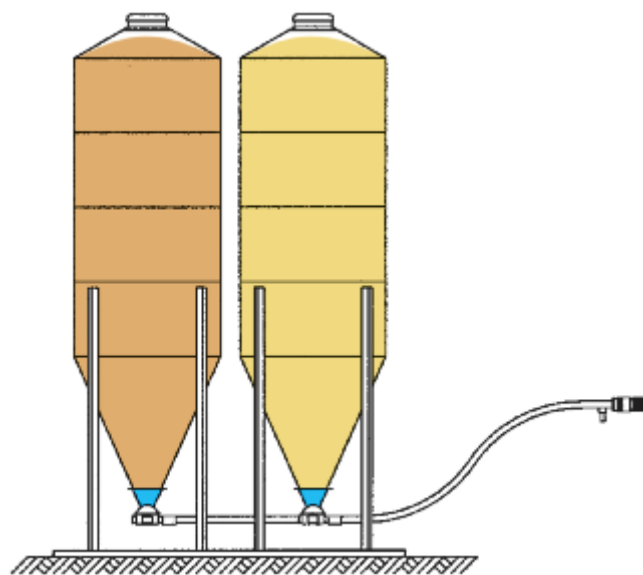

Flex Vey tandem system for two silos



Conveyor ch

Augers and Flex Vey for feed transport

With Big Dutchman feed conveying systems, your feed – be it meal, pellets or crumbs – passes from the silo into the house safely and without any loss of quality.

We offer augers and Flex Vey conveyor systems in a variety of sizes. For conveying capacities up to 4.5 t/h, the Flex Vey (spiral) is normally used.

In case of even higher capacities or pitches up to 75° it is the auger. In exceptional circumstances, even pitches up to 90° can be carried out (max. length of auger 10 m). Which system is the right one for you depends on your individual requirements.



Feeding augers for high conveying capacities



Flex Vey conveyor spirals – simple and flexible conveying systems

- ✓ our Flex Vey conveyor spiral comprises high-quality and extremely flexible spring steel;
- ✓ the feed can be transported into the house around bends of up to 90° safely, quickly and without feed separation;
- ✓ universal application for each type of house;
- ✓ for high conveying capacities;
- ✓ fast and easy assembly;
- ✓ can be driven by means of a V-belt motor or a gear motor.

ing feed from the silo into the house

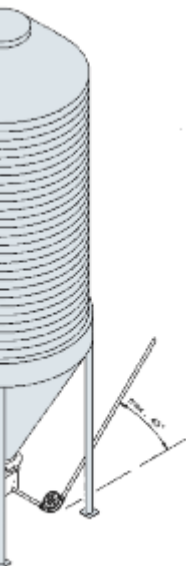

main (DR 850/DR 1500)

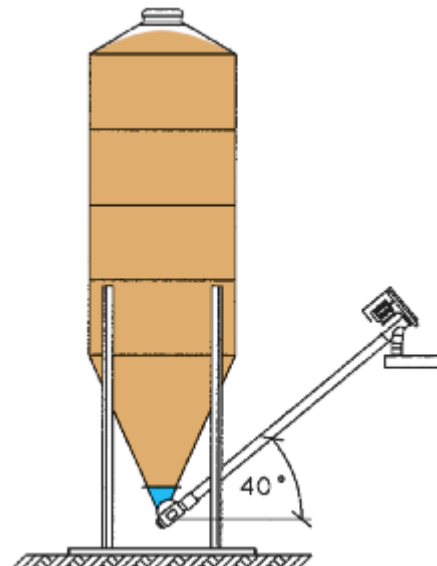

Vertical and cross conveying augers

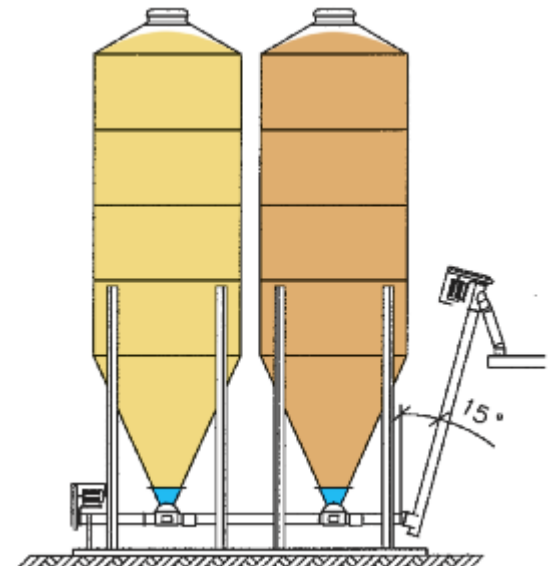

Tandem auger and forced transfer

Technical data and planning details for silos

Galvanized sheet steel silos

Type*	Code No.	Overall height (m)	Volume (m³)	Ø of the Silo (m)
BD-P	25-17-9410	3.5	4.1	1.80
BD-P	25-17-9420	4.4	6.3	1.80
R-P	25-17-6102	5.0	8.1	1.80
BD-P	25-17-9430	5.3	8.6	1.80
BD-P	25-17-9520	5.65	9.2	2.10
R-P	25-17-6103	5.84	10.2	1.80
R-P	25-17-6111	5.38	11.6	2.10
BD-P	25-17-9530	6.46	12.3	2.10
BD-P	25-17-9540	7.47	15.4	2.10
BD-P	25-17-9620	5.6	16.6	2.75
R-P	25-17-6113	7.0	17.4	2.10
R-P	25-17-6120	6.1	20.6	2.75
BD-P	25-17-9630	6.3	21.8	2.75
R-P	25-17-6121	6.89	25.0	2.75
BD-P	25-17-9640	7.0	27.0	2.75
R-P	25-17-6122	7.71	30.0	2.75
R-P	25-17-6123	8.52	35.0	2.75
R-P	25-17-6124	9.33	39.8	2.75

* silos, not assembled, also available with mechanic filling (BD-M, R-M)
 - more silo types available on request

Silos made of glass-fiber reinforced plastic

GRP silos are only offered fully fitted incl. filling and breather tube. They are available for holding from 4 to 60 m³ contents, with a height of 3.85 to 13.07 m in a great variety of types. They are corrosion-resistant and weatherproof as well as virtually maintenance-free.

Inside silos made of Trevira fabric

Inside silos consist of a Trevira bag and a steel stand. The silo bag with a 400 mm outlet has a sewn-on collar for connection to an auger box. These inside silos are available with volumes of 5.15 to 20.95 m³.

Type	Code No.	Overall height (m)	Volume (m³)
GS-1	25-30-3206	3.05	5.15
GS-A	25-30-3207	3.30	6.15
GS-B	25-30-3209	3.80	8.15
GS-C	25-30-3211	4.30	10.15
GS-D	25-30-3214	4.80	12.95
GS-E	25-30-3217	5.30	15.95
GS-F	25-30-3220	5.80	18.95
GS-G	25-30-3222	6.30	20.95

Note: The average weight of feed amounts to 0.65 t/m³
 Example: 8.4 m³ silo x 0.65 t/m³ = 5.5 t feed

Technical data and planning details for augers

Type	S102	S150	K150	TS200
conveying capacity horizontal* (t/h)	4.3	19	17	26
max. conveying length (m)	12	12	30	25
V-belt motor ** (kW)	0.75-2.2	1,1-3	1.5-5.5	2.2-5.5
motor speed (rpm)	400	400	400	150
outside diameter of tube (mm)	102	152	- ***	- ***
material	galvanized tube	galvanized tube	galvanized trough	galvanized trough
wall thickness (mm)	1.5	2	2	2

* with a bulk density of 0.65 t/m³ of the material to be conveyed; the conveying capacity decreases by approx. 30 % at a pitch of 45°

** gear motor also available on request; specifications for TS 200 for gear motor

*** open trough, also available with galvanized cover on request

Technical data and planning details for Flex Vey

Type	Flex Vey 75	Flex Vey 90	Flex Vey 125
conveying capacity horizontal* (t/h)	1.4	2.5	4.5
max. conveying length (m)	60	40	25
gear motor 370 rpm (kW)	0.55/0.75	0.75/1.1	1.5
V-belt motor 400 rpm (kW)	0.75	0.75	1.1
outside diameter of tube (mm)	75	90	125
material/wall thickness (mm)	PVC **/ 4	PVC **/ 4.3	PVC / 5
tube bend radius - 45°/90° (mm)	1540	1570	2750
outside diameter of spiral (mm)	60	70	100
pitch of spiral (mm)	60 ***	65	70

* the conveying capacity decreases by 30 % at a pitch of 45°

*** 40 mm also available on request

** galvanized tube also available on request



Big Dutchman.

Germany

Big Dutchman International GmbH
Big Dutchman Pig Equipment GmbH
 Postfach 1163 · 49360 Vechta · Germany
 Tel. +49 (0) 4447-801-0
 Fax +49 (0) 4447-801-237
 E-Mail: big@bigdutchman.de

Asia

BD Agriculture (Malaysia) Sdn. Bhd.
 No. 20, Lorong Keluli 1 B,
 Kawasan Perindustrian Bukit Raja,
 Seksyen 7, 40000 Shah Alam,
 Selangor Darul Ehsan · Malaysia
 Tel. +60-3-33 61 5555 · Fax +60-3-33 42 2866
 e-mail: bdasia@bigdutchman.com

USA

Big Dutchman, Inc.
 3900 John F. Donnelly Dr.
 Holland, MI 49422 · USA
 Tel. +1-616-392-5981 · Fax +1-616-392-6899
 e-mail: bigd@bigdutchmanusa.com