



Big Dutchman®



CallMatic 2

Electronic sow feeding
with advanced control system

CallMatic 2 – electronic sow feeding

Big Dutchman's electronic sow feeding system CallMatic 2 is a feeding system for pregnant sows in group management. It ideally combines the advantages of animal-friendly housing and a feeding method ideally adapted to the requirements of each individual sow.

For the sows, group management means more freedom of movement, better health and more robustness.

Individual, computer-controlled feeding allows the feed supply to be precisely matched to the condition of the sow.

For the farm manager this means healthy sows, performance-oriented feeding and best use of the house surface area. CallMatic 2 also provides the opportunity to automatically select sows.

Operating principle

Each sow is identified by a transponder ear tag. When a sow enters the feeding station, which is always open when no sow is inside, she passes a light barrier. As soon as a sow has entered the station, the entrance door closes. The sow is identified by the computer by means of an antenna which is placed in the trough flap. If the sow is entitled to receive feed, the trough opens and feed is measured out in small amounts. Once the sow has finished eating, the trough flap closes again. If the sow is not entitled to receive feed, the trough remains closed. The entrance door re-opens after a set time delay and the next sow enters the station and automatically drives out the last sow if she remains in the station too long. If a sow leaves the station even though she is still entitled to receive feed, the feeding stops and the sow can retrieve her remaining share some other time.



Technical features

- ✓ feed trough made of stainless steel, no traps and crevices for dirt, hence easy cleaning;
- ✓ very precise feed metering, hence no after-flow;
- ✓ additional hopper for feed additives (optional);
- ✓ colour-marking unit with up to 3 colours (optional);
- ✓ automatic selection;
- ✓ estrus detection (optional);
- ✓ metal parts which are located close to or on the floor are made of stainless steel thus providing protection against corrosion.



Feed trough made of stainless steel with trough flap open/closed



Foot made of stainless steel

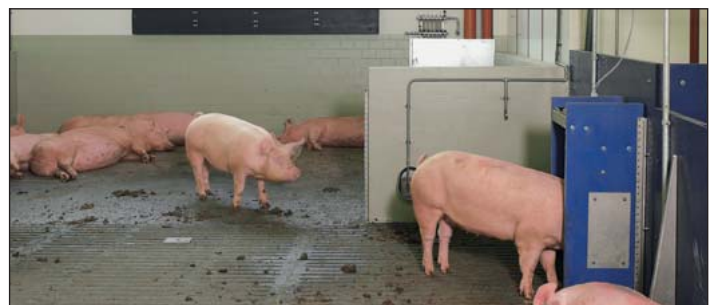

Estrus detection (optional)

Sow identification with high identification accuracy

Data collection and sow identification is carried out by a very reliable transponder which is inserted into the sow's ear by means of special pliers. This passive transmitter works without a battery.

The sow is identified by means of an antenna in the trough area of the station. An additional antenna for heat detection can be installed at the boar pen. Ear tags from different manufacturers can be identified without problems.



Small and light-weight ear tag for rapid data transfer

Advantages of the ESF station

- ✓ Management of large groups (max. 60 sows) per station
→ animal-friendly and economic housing system;
- ✓ individual feeding of all sows – dry or liquid – based on the current condition of the individual sow, for a better overall condition and healthy animals;
- ✓ solid side partitions for undisturbed feed intake;
- ✓ rugged construction;
- ✓ pneumatic opening of doors, the entrance door is open when the station is empty which makes the training of gilts much easier;
- ✓ modular design, which means every station can be customized to the individual requirements on every farm;
- ✓ use of sound absorbing materials ensures a low noise level in the area surrounding the station;
- ✓ emergency opening of the feeding station thanks to movable side partitions.

Control system – advanced computer technology for modern sow management

Big Dutchman's newly developed control system for the CallMatic 2 ESF station is based on state-of-the-art computer technology.

The control software allows for continuous data collection and real-time control and monitoring of all connected feeding stations. The modular design of the software permits the operator to control a virtually unlimited number of stations and connect an estrus detector without additional control elements. The control system provides individual visualisation of data and results and furthermore transmits current images directly from the barn.



A network camera permits to transmit images directly from the house to the office PC

Reliable and user-friendly operation

The station computer has a clearly arranged display and shows important information such as the number of visits to the station, the amount of feed consumed or the current status of the identified sow. All data is directly accessible.

Another advantage is that the station computer does not have to be installed at the ESF station but can also be installed in the walkway. This makes for better accessibility (animal-free area) so that adjustments can easily be made.

In addition to the station computer, it is possible to connect a separate PC which can for example be located in the farm office or the farm manager's home. Both computers communicate in real-time.



Station computer in the walkway – adjustments can be made without problems

The most important features of the computer control unit

- ✓ thanks to the modular design, it is possible to control a virtually unlimited number of ESF stations;
- ✓ every ESF station has a station computer that works independently of the central office PC which provides a rapid and reliable mode of operation and high system stability;
- ✓ the adjustments for all connected ESF stations can also be carried out from the office PC;
- ✓ freely-programmable feed curves are displayed graphically on the PC;



- ✓ start of feeding, metering speed and after-feeding times can be freely selected;
- ✓ the heat detection unit is also controlled by the station computer (no additional electronic equipment required);
- ✓ sows needing special attention are identified by the control system and automatically selected; the operator defines when and why a sow needs special attention;
- ✓ new sows can easily be added by entering the sow and transponder number and assigning an individual feed curve;



- ✓ a sensor at the exit door leading to the selection area registers the number of selected pigs and prevents overstocking of the selection pen;
- ✓ the integrated sow manager device allows the operator to filter the sows, change their status or their feed ration;
- ✓ a handheld computer is available as a mobile management tool.



Decisions made during the inspection round, such as an alteration of the feed curve, can easily be transferred to the PC later on.

Central selection – economic solution for large groups

Especially in large, dynamic groups the selection of individual sows is a recurring task which can be made a lot easier with the right technical support. For this reason Big Dutchman offers you the possibility of central selection as an alternative to the selection at each feeding station. Central selection allows you to manage groups of up to 300 sows.

The most important factor for a trouble-free operation is the right layout of the selection system. There are different possibilities, depending mainly on the house layout, the group size and the type of housing system – with or without straw. Up to 6 ESF stations can be connected to one selection unit. This solution is not only cost-effective but it is also very flexible as far as planning of the house is concerned.



Housing option with central selection

CallMatic 2 – dry feeding

Each feeding station is equipped with one feed hopper per feed type (max. 2). The hoppers are supplied from the respective silos. The feed hopper of the last feeding station of a group of feeding stations is equipped with a sensor. If the feed level drops below a set minimum value, the sensor triggers a signal and all feed hoppers are filled again.

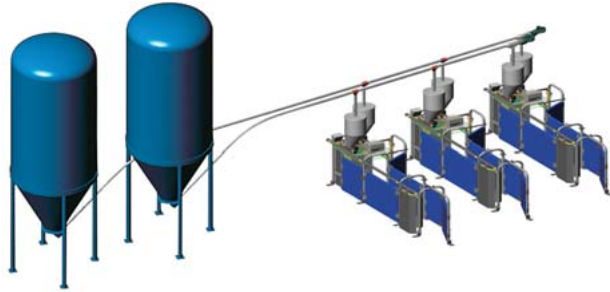
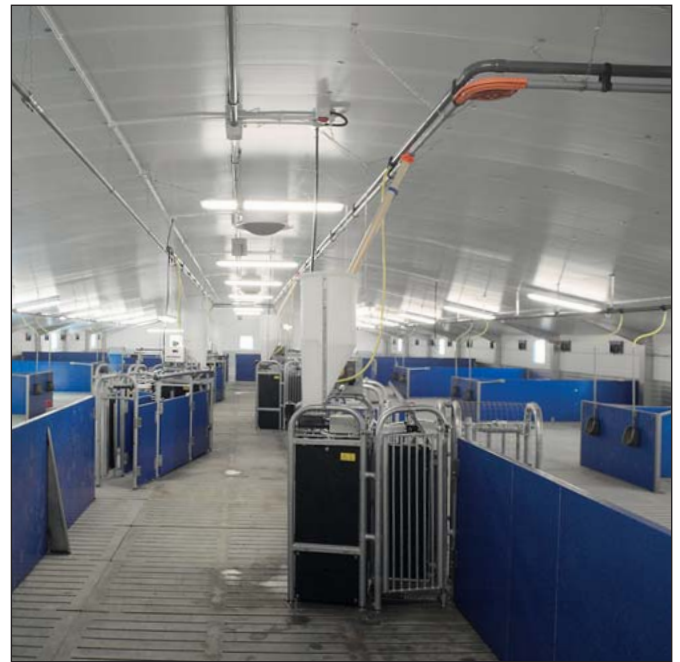

Diagram of a CallMatic 2 with dry feeding system



CallMatic 2 with dry feeding and selection into the aisle

CallMatic 2 – computer-controlled liquid feeding

The installation of an ESF system with liquid feed is particularly cost-effective if other pigs are already supplied with liquid feed by means of a compatible liquid feeding system. In this case, the computer of the ESF system is able to communicate with the liquid feeding system control. That means

the ESF system requests feed from the liquid feeding system which in turn starts to prepare a feed ration and pumps it into the feed tanks of the ESF system.

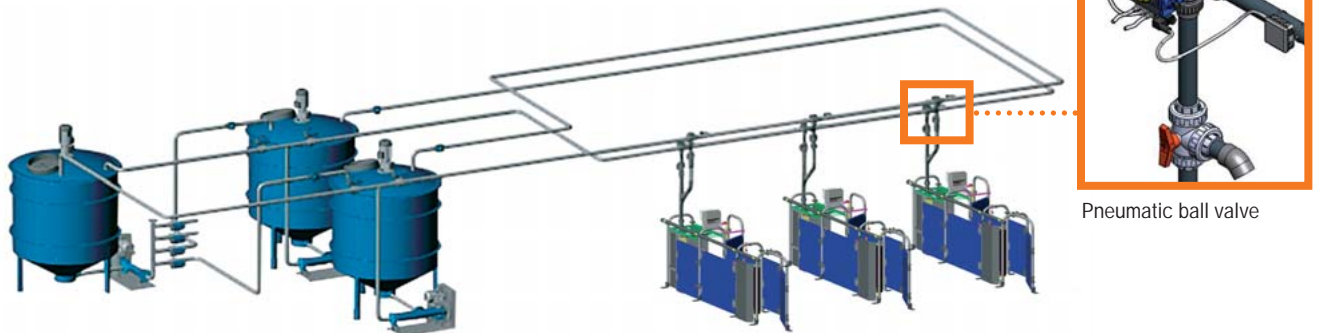

Diagram of computer-controlled liquid feeding using two types of feed (two storage tanks and two pipe lines required)

The liquid feed circulates through the pipes installed above the ESF stations. If a sow that is entitled to receive feed is identified, the newly developed, low-maintenance, pneumatic three-way ball valve opens. Feed is dispensed into the trough over a certain time interval which can be set by the farmer. This process is repeated until the sow has received her predetermined feed ration.

The exact amount that is to be dispensed is determined by weighing the feed in the mix tank. If the feed in the mix tank drops below a certain minimum, new feed is requested from the liquid feeding system. Through this method the entire system is constantly calibrated thus achieving a very high dosing accuracy during the entire feeding process.



Liquid feeding system HydroMix for supply of CallMatic 2

Housing options and space requirements when using CallMatic 2

CallMatic 2 has been designed for flexible handling of space and can therefore be integrated into many building plans, including older existing houses with difficult dimensions.

The following points are especially important:

- ✓ sufficient space in front of the feeding station;

- ✓ separation of lying and activity areas;
- ✓ installation of drinkers in the activity area (10-12 sows/drinker).

Let our experts advise you on all the options Big Dutchman offers you for successful sow management.

Waiting area with ESF station for 60 sows in a steady group

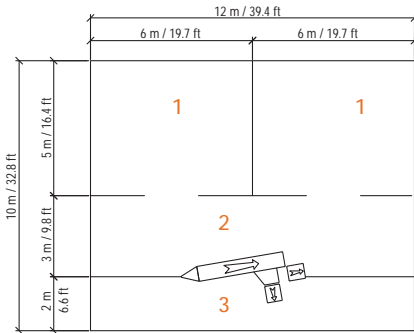

Waiting area with 4 ESF stations for 200 – 240 sows in a dynamic group

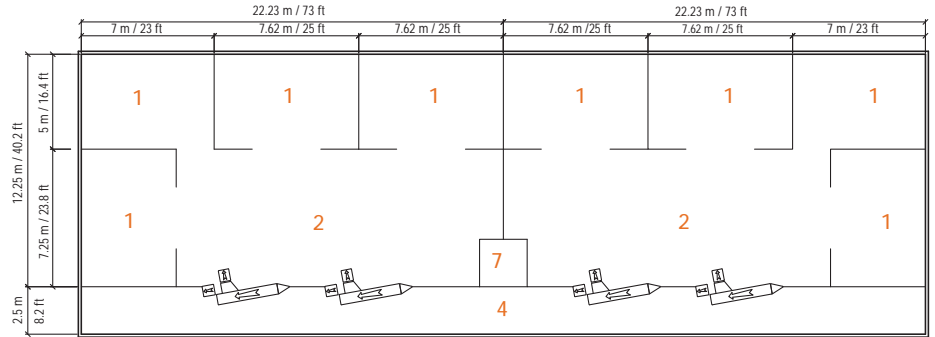

Housing design example with central selection

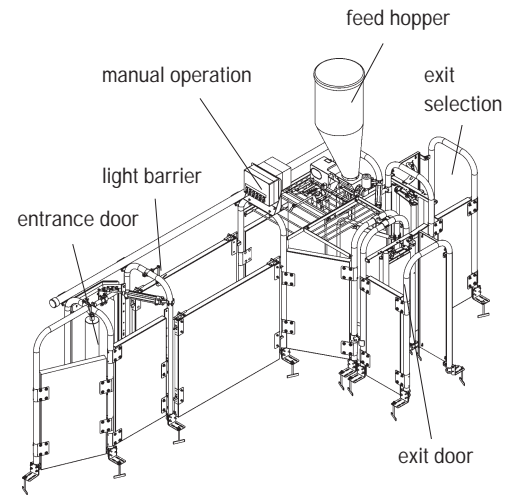
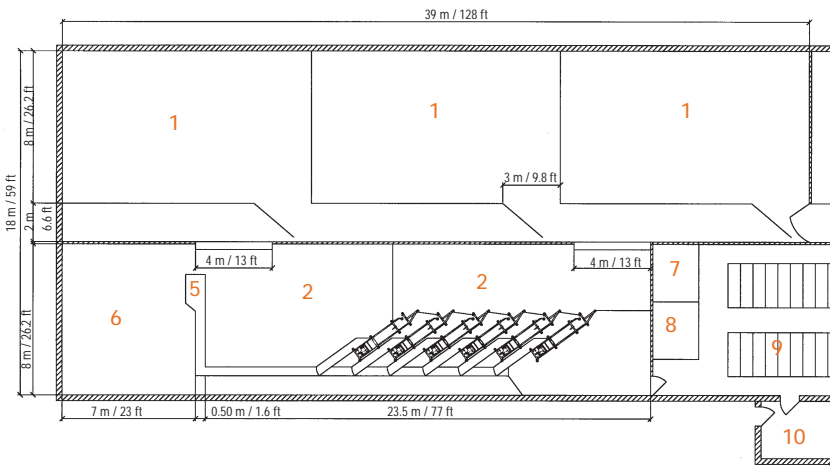

Legend

- | | |
|---|----------------------------------|
| 1 resting pens with or without straw | 6 central selection pen |
| 2 activity area with slatted floor | 7 boar pen with estrus detection |
| 3 selection and training pen with slatted floor | 8 gilt pen |
| 4 selection into the aisle with slatted floor | 9 crates |
| 5 selection unit | 10 service room |



Big Dutchman®

Big Dutchman Pig Equipment GmbH
 P.O.Box 1163 • 49360 Vechta • Germany
 Tel. +49(0)4447-801-0 • Fax +49(0)4447-801-237
 www.bigdutchman.de • E-Mail: big@bigdutchman.de

